

# Construction of Dye-Sensitized Solar Cells Using Natural Plants

Okidim Samuel Horsfall

Faculty of Natural Science, Ignatius Ajuru University of Education, Rivers State, Nigeria

---

## **Abstract**

Dragon fruit dye has been prepared and used in the fabrication of DSSC as sensitizer. The properties of dragon fruit dye have been investigated by UV-Vis and FTIR technique. The absorption spectrum shows a peak value of 535 nm. Chemically dragon fruit dye shows present of intermolecular H-bond, conjugate C=O stretching and esters acetates C-O-C stretching vibration, which is due to the component of anthocyanin. On the other hand, the resistivity of TiO<sub>2</sub> film on ITO glass before it is used for the fabrication of DSSC is also investigated. The TiO<sub>2</sub> sheet resistivity increase from 1 layer = 22.1 Ω cm to 2 layers = 369.6 Ω cm. Finally, the efficiency of assemble DSSC was evaluated and simulated using a custom made technique. The result shows fill factor, P<sub>max</sub> and efficiency during the present of halogen lamp are 0.30, 13 μW, 0.22%, respectively. We have successfully showed that the DSSC using dragon fruit as a dye sensitizer is useful for the preparation of environmental friendly and low-cost DSSC.

Keywords: dye-sensitized solar cell, natural dyes, TiO<sub>2</sub> film

---

## 1. INTRODUCTION

Dye-sensitized solar cell (DSSC) is the third generation of solar cell which has been developed by O'Regan and Gratzel in 1991 [1]. This simple assemble of solar cell (also known as photovoltaic device) works by converting inexpensive photon from solar energy to electrical energy, based on sensitization of wide bandgap semiconductor, dyes and electrolyte [2,3]. The advantages of DSSC are that it can be engineered into flexible sheets, low cost of sensitization material production, ease of fabrication and low process temperature. Due to the low cost of the overall production of DSSC, it has been expected that the DSSC type of solar cell will give a higher return of investment (ROI) when compared to Silicon based solar cell (Si-SC).

The performance of the DSSC is highly dependent on the sensitizer dye and wide bandgap material such as  $\text{TiO}_2$ ,  $\text{ZnO}$  and  $\text{Nb}_2\text{O}_5$  [3]. Material  $\text{TiO}_2$  is highly preferable due its ability of the surface, to resist the continuous transfer of electron under illumination solar photon (ultra-violet range). The performances of dye absorption spectrum which is mounted on the surface of  $\text{TiO}_2$  molecular are important aspects to determine the efficiency of the solar cell [4,5].

One of most efficient sensitizer is produced from heavy transition metal coordination compound, which is ruthenium polypyridyl complex [6]. This complex is used widely due to its intense charge-transfer (CT) absorption in visible light spectrum; good absorption, long excited lifetime and highly efficient metal-to-ligand charge transfer (MLCT). However, the ruthenium based complex is very expensive and hard to prepare. Thus, an alternative organic dye such as natural dyes is suggested with similar characteristic with high absorption coefficients [7-13]. The good side of natural dyes is includes their availability, environmental friendly and low in cost.

The ability of sensitizers in the natural dye is link to Anthocyanins properties [14-21]. Anthocyanin molecule in the form of carbonyl and hydroxyl which occurs naturally in fruit,

leaf and flowers is responsible to show types and colour pigment in visible red-to-blue spectrum. In the previous reports, various natural source of Anthocyanin gives variety of sensitized performance.

In this paper, the DSSC is prepared using natural fruit dye extracted from dragon fruits (*Hylocereus costaricensis*), which used as sensitizer. Dragon fruit based dye has been selected due to its widely available in local area and low in conservation cost. The dye absorption spectrum,  $\text{TiO}_2$  electrical properties and DSSC efficiency is then investigated.

## 2. BASIC OPERATION OF DYE-SENSITIZED SOLAR CELL (DSSC)

Figure 1 shows the complete structure of our DSSC. Under illumination of sun light energy, photon will strike through conductive layer glass; Indium-doped Tin Oxide (ITO) towards dye molecules which mount on the surface of  $\text{TiO}_2$  particles. The photon excitation of dye will cause an injection of an electron into conduction band of the  $\text{TiO}_2$  layer. These electrons will circulate the external loop through the load.

Meanwhile, dye molecule which had lost electron will be restored by electron donation from redox electrolyte (contain iodide/triiodide), which in this experiment; a mixture of Potassium Iodide (KI) and Iodine ( $\text{I}_2$ ) [3]. This process occurs very fast avoiding any recombination of electrons rejected earlier.

Under illumination, voltage is generated through potential difference between Fermi level of  $\text{TiO}_2$  layer and redox electrolyte.

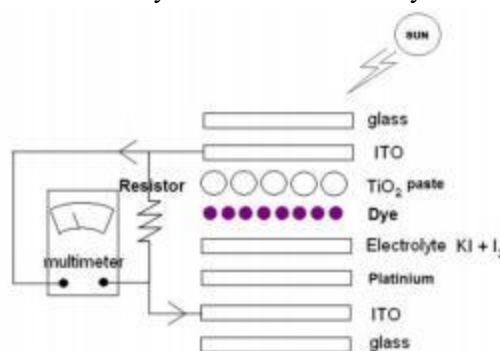

Fig. 1 The cross section assemble consist of ITO glass,  $\text{TiO}_2$  film, dragon fruit dye, electrolyte and platinum layer on ITO glass,

arranged to form complete circuit of dye-sensitized solar cell.

### 3. EXPERIMENTAL SETUP

#### 3.1 Preparation of natural dragon fruit dye

Fresh dragon fruit flesh of weight 50g is mix into 50ml of distillate water (DI) with a ratio of 1:1 at room temperature. The mixture is blend for 10 minute until mixture show homogenous in color. The cocktail then undergoes centrifuge (Refrigerated centrifuge; HERMLE Z323K) at 3000 rpm for 25 minute at 25°C. Dropper been used to collect dye pigment at center of the test tube and use for Ultraviolet-visible Spectroscopy (UV-Vis) and Fourier Transform Infrared Spectroscopy (FTIR) analyses.

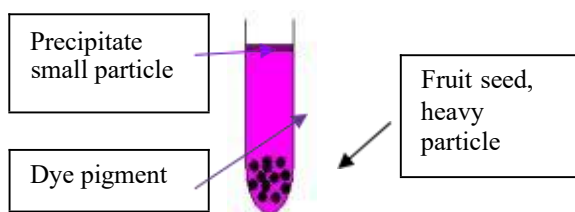

Figure 2 : The test tube portion after centrifuge at 3000 rpm, about 25 minutes at 30 °C.

#### 3.2 Preparation of conductive ITO glass

Conductive ITO coated glass was purchased from Farnell. Initially, the ITO glass shows resistivity reading of 19  $\Omega$ /cm using a multimeter measurement. Then, two piece of conductive glass were merged separately into two identical beaker containing 10 ml of 95wt.% ethanol solution. Both of the beakers undergoes ultrasonic bath for 25 minutes at medium mode. The resistivity of ITO coated glass decreased to 17  $\Omega$ /cm after the cleaning process.

#### 3.3 Preparation of TiO<sub>2</sub> paste and counter electrode

A porous film TiO<sub>2</sub> paste is prepared using technique reported by Wongcharee et al., 2007. Commercial TiO<sub>2</sub> nanoparticles of 0.2g (Sigma – Aldrich; 634662) is blended using an agate

mortar with 0.4 ml nitric acid solution (0.1M), 0.08g of polyethylene glycol (MW 10,000) and one drop of nonionic surfactant, Triton X-100. Blending process continued using ultrasonic bath for 30 minutes until it forms thick paste without any clots.

A piece of conductive glass is selected and placed on a metal sheet. A Scotch tape at four sides was used as masking material on the conductive layer to restrict the thickness and area of the paste. Spread thin layer using glass rod on guided area of 1 cm x 1 cm hole. Later, the glass is sintered at 450°C for 2 hours under thermal furnace module.

After the annealing process, when the temperature of the film paste drops to 50 – 70°C, the coated glass is immerse into natural dye solution and leave for 24 hours. Excess non-adsorbed dye, were washed using with anhydrous ethanol.

Platinum (Pt) plated glass is prepared by sputtering deposition (JEOL 1601) technique using Pt target at 40mA for 30 second on another conductive glass surface. The thickness of Pt thin film is approximately 20nm. This layer will known as counter electrode in the solar cell configuration.

#### 3.4 I-V characterization

The electrical current-voltage (I-V) curve properties of the TiO<sub>2</sub> film coating were obtained using four hand probe shown in figure 3 and 4. Figure 3 shows the cross section of setup of metal contact on TiO<sub>2</sub> film, which is needed for four point probe measurement. The metal contact is prepared using Pt target on the TiO<sub>2</sub> film with thickness of approximately 20nm by sputter coater.

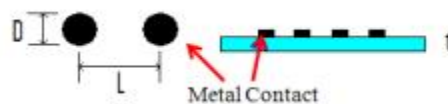

Fig. 3 : The cross-section diagram of TiO<sub>2</sub> film with metal contact

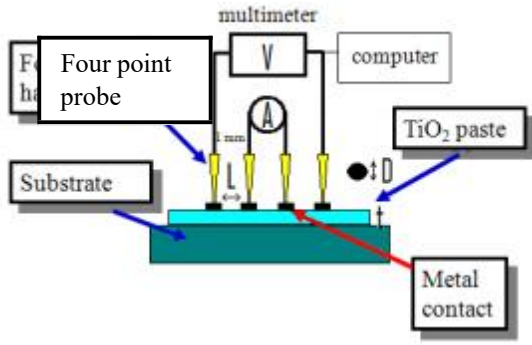

Fig. 4 : Computerized four hand probe diagram to characterize TiO<sub>2</sub> film with metal contact

Computerized four hand probe is used to obtain voltage (V) and current (I) value of the TiO<sub>2</sub> film. Figure 4 shows the arrangement of the four point probe experiment. From the I-V curve result, the sheet resistivity, R<sub>s</sub> of prepared TiO<sub>2</sub> film can be calculated as shown in equation 1.

$$R_s = (V / I) \times (A / L) \quad (1)$$

Where (V / I) refers to resistance, Ω, while A refers to area which is diameter (D) of the metal contact times with thickness (t) of the film and L refers to distance between metal contact. The unit is in Ω . cm. The TiO<sub>2</sub> film thickness over formation layer is obtained using surface profiler.

### 3.5 Full assemble of DSSC and its analysis

First, the TiO<sub>2</sub> film coated glass was immerse into the dragon fruit dye for about 24 hours until the white color of TiO<sub>2</sub> film becomes light purple in color.

Then, the electrolyte solution is prepared using technique published in reference [21], which is as sandwich material between the dye coated TiO<sub>2</sub> layer and counter electrode material. The electrolyte solution (0.5M potassium iodide (KI) and 0.05M iodine) is prepared.

Small amount of sealant of magic tape is applied around TiO<sub>2</sub> material area. This will created trapped boundaries to avoid any leak of

electrolyte solution in the solar cell. The electrolyte liquid is inserted between the space of the electrodes by capillary action. Binder clips are used to hold the electrodes together. The Pt thin film was coated on ITO coated glass of the other electrode. Figure 5 shows the full assemble of DSSC.

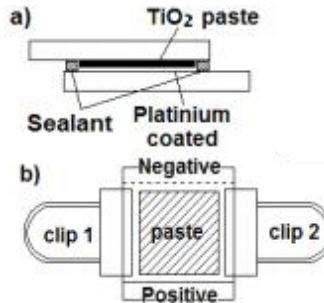

Fig. 5 : The full assemble of DCCS. a) The cross-section view. b) the top view with binder clip on both side.

Solar energy conversion efficiency consist of photocurrent-voltage (I-V) characterization curve been obtain using modified computerized digital Keithley multimeters under illumination of 50W halogen lamp (Osram.). Note that this is a homemade solar simulation system which has been tested using the standard silicon solar cell. From the resultant I-V graph, the fill factor of the DSSC can be calculated as shown in equation 2 [6,21].

$$FF = (I_{max} \times V_{max}) / (I_{sc} \times V_{oc}), \quad (2)$$

Where  $I_{max}$  and  $V_{max}$  referred to maximum photocurrent and photovoltage at maximum power output ( $P_{max}$ ). While the  $I_{sc}$  referred to short-circuit photocurrent and  $V_{oc}$  is referred to open-circuit photovoltage. Then, the efficiency of the solar cell is defined as equation 3,

$$\eta = P_{max} / P_{in}, \quad (3)$$

where  $P_{in}$  is the illumination input power at surface of the DSSC.

## 4. RESULTS AND DISCUSSION

### 4.1 Ultraviolet-visible spectroscopy (UV-Vis)

The absorption spectrum of dragon fruit was obtained using UV-Vis. The wavelength range of spectrum lays between 400nm to 900nm. The related spectrum is shown in figure 6.

It found that, the dragon fruit dye have peak absorption at 535nm. The dragon fruit show good absorption level between 450nm to 600nm. From the result, it is understood, dragon dye will absorb light range from 450nm to 600nm wavelength. Remaining spectrum will reflect showing a mixture of red and blue colour (similar to purple) with a under white light.

The similar result was found for extract rosella and blue pea which has been reported by Wongcharee *et. al.* Basically, this absorption is due to the anthocyanin obtain in the dragon fruit.

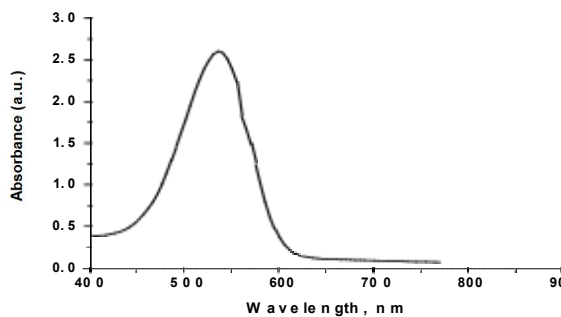

Fig. 6 : The dye absorption spectrum of dragon fruit dye in range of 400 nm to 900 nm.

### 4.2 Fourier Transform Infrared Spectroscopy (FTIR)

The result from FTIR shows three main peak in absorbance wavenumbers spectrum range from 4000  $\text{cm}^{-1}$  to 600  $\text{cm}^{-1}$ . The result is shown in figure 7.

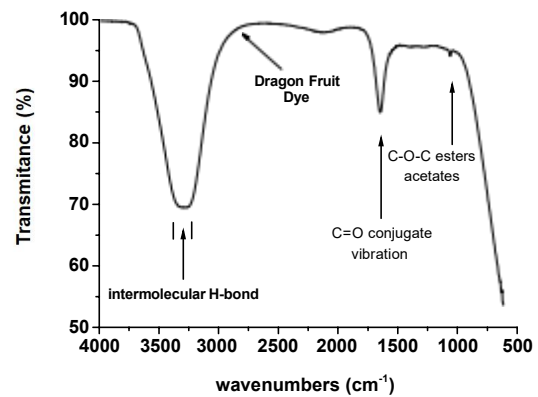

Fig. 7: The FTIR result of dragon fruit dye ranging from 4000  $\text{cm}^{-1}$  to 600  $\text{cm}^{-1}$ .

From the result obtain, the broad absorption range between 3200 ~ 3400  $\text{cm}^{-1}$  show the chemical have intermolecular H-bond and sharp absorption between 1600 ~ 1700  $\text{cm}^{-1}$  shows that C=O stretching vibration is conjugate. The sharp peak at 1030 ~ 1060  $\text{cm}^{-1}$  is C-O-C stretching vibration of esters acetates.

Results shown in figure 6 and 7 prove that the dragon fruit dye contained the anthocyanin which is the core composition for natural dye in DSSC. The carbonyl and hydroxyl groups in dragon fruit dye can be bound with the surface of  $\text{TiO}_2$  film and thus result in the photoelectric conversion effect [6]. Further investigations on the molecular structure of dragon fruit dye will be carried out in the future.

### 4.3 $\text{TiO}_2$ film resistivity

From the equation (1), the sheet resistivity can be calculated for 1 and 2 layers of  $\text{TiO}_2$  film. The results are shown in table 1.

In this experiment, ITO film with the thickness of  $1.0 \times 10^{-5}$  cm has been used. The sheet resistivity of three types of sample consists of ITO substrate without any  $\text{TiO}_2$  film, ITO with single layer masking and double layer tape thickness  $\text{TiO}_2$  film are  $2.1 \times 10^{-5} \Omega$  cm,  $22.1 \Omega$  cm and  $369.6 \Omega$  cm, respectively. From the result above, it shows that, when the thickness value of the  $\text{TiO}_2$  film increase, the sheet resistivity value increase simultaneously. It cause the electrical properties of the sample

have change from conductor to semiconductor range as the thickness value increase [22]. Further investigation on the crystallinity due to grain boundaries effect is needed to explain the situation.

Table 1 : Thickness and resistivity over number of masking layer during TiO<sub>2</sub> film preparation.

Parameter	ITO without TiO <sub>2</sub> film	ITO + 1 layer TiO <sub>2</sub> film	ITO + 2 layer TiO <sub>2</sub> film
Averaged thickness	1.0 x 10 <sup>-5</sup> cm (ITO thickness)	1.7 x 10 <sup>-3</sup> cm (TiO <sub>2</sub> thickness)	4.4 x 10 <sup>-3</sup> cm (TiO <sub>2</sub> thickness)
V / I, Resistance	2.1 Ω	1.3 x 10 <sup>4</sup> Ω	8.4 x 10 <sup>4</sup> Ω
Diameter of MC	0.1 cm	0.1 cm	0.1 cm
Distance between MC	0.1 cm	0.1 cm	0.1 cm
Sheet resistivity, R <sub>s</sub>	2.1 x 10 <sup>-5</sup> Ω cm	22.1 Ω cm	369.6 Ω cm
Properties	Conductive	Semiconductor	Semiconductor

#### 4.4 Efficiency of DSSC

From the full assemble DSSC, it is interesting to evaluate the solar energy conversion efficiency. Under irradiation of halogen lamp in a black box, figure 8 shows reading of 3 different conditions recorded from -600 mV to 600 mV with no halogen illumination, with halogen illumination and simulated curve with higher efficiency.

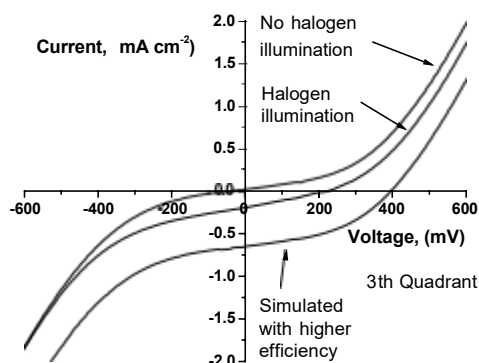

Fig. 8 : The DSSC conversion efficiency test for sample of with and without halogen illumination and simulated reading with higher efficiency.

Properties of solar cell can be determined when it is under homemade 5.8 mW/cm<sup>2</sup> halogen illumination. The I-V curve will have a phase shift to lower y-axis during the halogen illumination. Higher efficiency of DSSC is expected to show higher y-axis shift as in the figure 8. This simulation curve is simulated in order to show any higher efficiency of solar cell is present. On the other hand, when there is no halogen illumination present, the curve intercepts the origin value.

To calculate the efficiency, value that undergoes 4<sup>th</sup> quadrant will be taken under consideration with inverted photocurrent value to positive range. The resultant graph taken from the 4<sup>th</sup> quadrant of I-V curve in figure 8 is shown in figure 9.

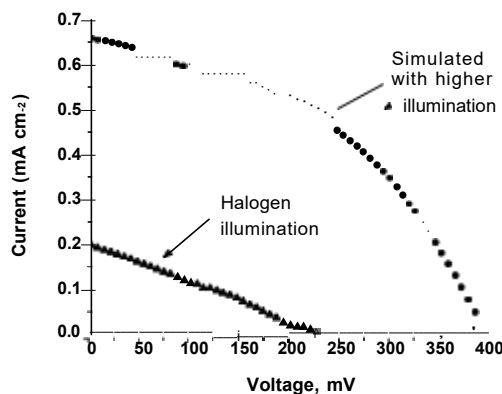

Fig. 9 : The 4th quadrant region result of tested halogen illumination and simulation of higher illumination expected result.

In the fig. 9, the result of halogen present test result shows almost a straight line cutting through 220 mV while the simulation based curve shows intercept at 400 mV. The efficiency ( $\eta$ ) and fill factor (FF) of fabricated has been calculated using equation 2 and 3 are shown in table below.

Table 2 : Photoelectrochemical parameter of DSSC of halogen present and simulation curve result

Sample	$I_{sc}$ (mA $cm^{-2}$ )	$V_{oc}$ (mV)	FF	$P_{max}$ ( $\mu$ W)	$\eta$ %
Halogen present	0.20	220	0.30	13	0.22
Higher efficiency	0.63	400	0.44	112	1.91

The fill factor,  $P_{max}$  and efficiency of our DSSC using extracted dragon fruit dye are 0.30, 13  $\mu$ W, 0.22%. From the result, it is proven that extracted dragon fruit dye is applicable for DSSC preparation. Therefore, the dragon fruit extract could be an alternative anthocyanin source for DSSC preparation especially in the tropical country such as South East Asia.

Further investigations on the technique of extraction the dragon fruit dye is essential in order to improve the efficiency. It has reported that the extracting temperature, solvent and pH are affecting the efficiency of DSSC using natural dyes [21].

## 5. CONCLUSION

Dragon fruit dye has been prepared and used in the fabrication of DSSC as sensitizer. The dragon fruit show good absorption spectrum between 450nm to 600nm with peak value of 535 nm. The preparation of  $TiO_2$  film on ITO glass shows the increase in sheet resistivity as layer of masking increase from 1 layer = 22.1  $\Omega$  cm to 2 layers = 369.6  $\Omega$  cm. Full DSSC fabrication shows fill factor,  $P_{max}$  and efficiency of halogen present are 0.30, 13  $\mu$ W, 0.22%, respectively. Therefore, the natural dye extracted from dragon fruit shows potential to be used as green energy generator In future, the use of  $TiO_2$  film from the paste type to a thin film is suggested, as it will improve the connectivity between the  $TiO_2$  film and dye.

## REFERENCES

- [1] B. O'Regan and M. Grätzel, "A low-cost, high-efficiency solar cell based on dye-sensitized colloidal  $TiO_2$  films" *Nature* 353 (1991) pp. 737 – 740.
- [2] J. Bisquert, J. García-Cañadas, I. Mora-Seró and E. Palomares. "Comparative analysis of photovoltaic principles governing dye-sensitized solar cells and p-n junctions". *Journal Spin Use* 6 (2003) p.p 5215.
- [3] M. Gratzel. "Dye-sensitized solar cell". *Journal of Photochemistry & Photobiology C* 4 (2003) pp. 145.
- [4] K. Tennakone, G.R.R.A. Kumara, A.R. Kumarasinghe, P.M. Sirimanne and K.G.U. Wijayantha. "Efficient photosensitization of nanocrystalline  $TiO_2$  films by tannins and related phenolic substances". *Journal of Photochemistry & Photobiology A* 91 (1996) pp. 217-220.
- [5] J. Bisquert, D. Cahen, G. Hodes, S. Rühle and A. Zaban. "Physical chemical principle of photovoltaic conversion with nanoparticulate, mesoporous dye-sensitized solar cells". *Journal Physical Chemistry B*, 108 (2004), pp. 8106 – 8118.
- [6] S. Hao, J. Wu, Y. Huang and J. Lin. "Natural dyes as photosensitizers for dye-sensitized solar cell". *Journal Solar Energy*. 80 (2006) pp. 209 – 214.
- [7] K.Hara, Y.Dan-Oh, C.Kasada, H.Arakawa, "Effects of additives on the photovoltaic performance of coumarin - dye-sensitized nanocrystalline  $TiO_2$  solar



- cells”, *Langmuir* 20 (2004) p.p 4205–4210.
- [8] S. Kim, J.K. Lee, S.O. Kang, J.J. Ko, J.H. Yum, S. Fantacci, F. De Angelis, D. DiCenso, Md.K. Nazeeruddin, M. Grätzel, “Molecular engineering of organic sensitizers for solar cell applications”, *Journal of American Chemical Society* 128 (2006) p.p 16701–16707.
- [9] S. Ito, S.M. Zakeeruddin, R. Humphry - Baker, P. Liska, R. Charvet, P. Comte, and others, “High-efficiency organic dye-sensitized solar cells controlled by nanocrystalline – TiO<sub>2</sub> electrode thickness”, *Advance Material* 18 (2006) p.p 1202–1205.
- [10] W.M. Campbell, K.W. Jolley, P. Wagner, K. Wagner, P.J. Walsh, K.C. Gordon and others, “Highly efficient porphyrin sensitizers for dye-sensitized solar cells”, *Journal of Physical Chemistry C* 111 (2007) p.p 11760–11762.
- [11] D.P. Hagberg, J.-H. Yum, H. Lee, F. De Angelis, T. Marinado, K.M. Karlsson, and others, “Molecular engineering of organic sensitizers for dye-sensitized solar cell applications”, *Journal of American Chemistry Society*, 130 (2008) p.p 6259–6266.
- [12] H. Choi, C. Baik, S.O. Kang, J. Ko, M.-S. Kang, M.K. Nazeeruddin, and M. Grätzel, “Highly efficient and thermally stable organic sensitizers for solvent-free dye-sensitized solar cells”, *Angewandte Chemie International Edition* 47 (2008) p.p 327–330.
- [13] D. Kuang, S. Uchida, R. Humphry-Baker, S.M. Zakeeruddin, M. Grätzel, “Organic dye-sensitized ionic liquid based solar cells : remarkable enhance mentin performance through molecular design of indulines ensitizers,” *Angewandte Chemie International Edition* 47 (2008) p.p 1923–1927.
- [14] S. Hao, J. Wu, Y. Huang, J. Lin, “Natural dyes as photosensitizers for dye-sensitized solar cell”. *Solar Energy* 80 (2006) p.p 209 - 214.
- [15] Y. Amao and T. Komori, “Bio-photovoltaic conversion device using chlorine-e6 derived from chlorophyll from Spirulina adsorbed on a nanocrystalline TiO<sub>2</sub> film electrode”. *Biosensors and Bioelectronics* 19 (2004) p.p 843- 847.
- [16] A.S. Polo, N.Y. Iha, “Blue sensitizers for solar cells: natural dyes from calafate and jaboticaba”. *Solar Energy Material and Solar Cells* 90 (2006) p.p 1936-1944.
- [17] C.G. Garcia, A.S. Polo and N.Y. Iha. “Fruit extracts and ruthenium polypyridinic dyes for sensitization of TiO<sub>2</sub> in photoelectrochemical solar cells”. *Journal of Photochemical and Photobiology A* 160 (2003) p.p 87-91.
- [18] G.P. Smestad, “Education and solar conversion: Demonstrating electron transfer”. *Solar Energy Material & Solar Cells* 55 (1998) p.p 157-178.
- [19] G.R.A. Kumara, S. Kanebo, M. Okuya, B. Onwona-Agyeman, A. Konno and K. Tennakone, “Shiso leaf pigments for dye-sensitized solid-state solar cell”. *Solar Energy Material and Solar Cells* 90 (2006) p.p 1220-1226.
- [20] N.J. Cherepy, G.P. Smestad, M. Grätzel and J.Z. Zang. “Ultrafast electron injection: implications for a photoelectrochemical cell utilizing an anthocyanin dye-sensitized TiO<sub>2</sub> nanocrystalline electrode”. *Journal of Physical Chemistry B* 101 (1997) p.p 9342 - 9351.
- [21] K. Wongcharee, V. Meeyoo and S. Chavadej, “Dye-sensitized solar cell using natural dyes extracted from rosella and blue pea flowers”, *Journal Solar Energy & Solar Cell* 91 (2007) pp. 566 – 571.
- [22] G. G. Gu, Z. He, Y. Tao, Y. Li, J. Li, H. Yin and others. “Conductivity of nanometer TiO<sub>2</sub> thin films by magnetron sputtering”. *J. Vacuum* 70 (2003) p.p 17-20.